

ARIA X2 IPH BRIDGE

User Manual

©2026 ELATION PROFESSIONAL all rights reserved. Information, specifications, diagrams, images, and instructions herein are subject to change without notice. ELATION PROFESSIONAL logo and identifying product names and numbers herein are trademarks of ELATION PROFESSIONAL. Copyright protection claimed includes all forms and matters of copyrightable materials and information now allowed by statutory or judicial law or hereinafter granted. Product names used in this document may be trademarks or registered trademarks of their respective companies and are hereby acknowledged. All non-ELATION brands and product names are trademarks or registered trademarks of their respective companies.

ELATION PROFESSIONAL and all affiliated companies hereby disclaim any and all liabilities for property, equipment, building, and electrical damages, injuries to any persons, and direct or indirect economic loss associated with the use or reliance of any information contained within this document, and/or as a result of the improper, unsafe, insufficient and negligent assembly, installation, rigging, and operation of this product.

Elation Professional USA | 6122 S. Eastern Ave. | Los Angeles, CA. 90040
323-582-3322 | www.elationlighting.com | info@elationlighting.com

Elation Professional B.V. | Junostraat 2 | 6468 EW Kerkrade, The Netherlands
+31 45 546 85 66 | www.elationlighting.eu | info@elationlighting.eu

Elation Professional Mexico | AV Santa Ana 30 | Parque Industrial Lerma, Lerma, Mexico 52000
+52 (728) 282-7070

DOCUMENT VERSION



Due to additional product features and/or enhancements, an updated version of this document may be available online. Please scan the QR Code with your mobile device or visit www.elationlighting.com for the latest revision/update of this manual, before installation and/or programming.

Date	Document Version	Software Version >	Modes	Notes
08/20/24	1	1.00	N/A	Initial Release
07/21/25	1.1	N/C	N/A	Updated: General Information, Overview, Installation Instructions, System Menu Frequency & Wireless Location Guidelines, Specifications; Added FCC Statement
01/21/26	1.2	N/C	N/A	Updated: General Information, Safety Guidelines, IP67 Rated, Installation Guidelines, Maintenance Guidelines, Specifications

CONTENTS

General Information	4
IP67 Rated	5
Safety Guidelines	6
Overview	7
Connections	8
Installation Instructions	9
Setup	13
System Menu	14
Frequency & Wireless Location Guidelines	16
Firmware Update	17
Maintenance Guidelines	18
Torque Settings for Screws	19
IP Test Parameters	20
Specifications	21
Dimensional Drawings	22
FCC Statement	23

GENERAL INFORMATION

FOR PROFESSIONAL USE ONLY

INTRODUCTION

Please read and understand the instructions in this manual carefully and thoroughly before attempting to operate this device. These instructions contain important safety and use information.

UNPACKING

Every device has been thoroughly tested and has been shipped in perfect operating condition. Carefully check the shipping carton for damage that may have occurred during shipping. If the carton is damaged, carefully inspect the device for damage, and be sure all accessories necessary to install and operate the device have arrived intact. In the event damage has been found or parts are missing, please contact our customer support team for further instructions. Please do not return this device to your dealer without first contacting customer support. Please do not discard the shipping carton in the trash. Please recycle whenever possible.

CUSTOMER SUPPORT

Contact ELATION Service for any product related service and support needs. Also visit forums.elationlighting.com with questions, comments or suggestions.

ELATION SERVICE USA - Monday - Friday 8:00am to 4:30pm PST

323-582-3322 | support@elationlighting.com

ELATION SERVICE EUROPE - Monday - Friday 08:30 to 17:00 CET

+31 45 546 85 63 | support@elationlighting.eu

REPLACEMENT PARTS please visit parts.elationlighting.com

LIMITED WARRANTY

For up-to-date warranty information regarding your device, please visit Elation's warranty information page online or scan the QR codes below.



USA: <https://www.elationlighting.com/warranty-information>



EU: https://www.elationlighting.eu/terms_and_conditions

It is strongly recommended to power the fixture down completely when not in use. Doing so will reduce wear on the fixture due to sustained or extended operational periods, thereby maximizing its operational lifespan.

IP67 RATED

The **International Protection (IP)** rating system is commonly expressed as “**IP**” (Ingress Protection) followed by two numbers (i.e. IP67), where the numbers define the degree of protection. The first digit (Foreign Bodies Protection) indicates the extent of protection against particles entering the fixture, and the second digit (Water Protection) indicates the extent of protection against water entering the fixture. An **IP67** rated lighting fixture is designed and tested to protect against the ingress of dust (**6**), and immersion in water to a depth of 1 meter (**7**).

NOTE: THIS FIXTURE IS INTENDED FOR TEMPORARY OUTDOOR USE ONLY!

Maritime/Seaside Environment Installations: A maritime/seaside environment is adjacent to the sea and caustic to electronics through exposure to atomized salt water and humidity, whereas a coastal environment extends 5 miles inland.



NOT suitable for maritime/seaside environment installations. Installing this fixture in a maritime/seaside environment may cause corrosion and/or excessive wear to the interior and/or exterior components of the fixture. Damages and/or performance issues resulting from installation in a maritime/seaside environment will void the manufacturer’s warranty, and will NOT be subject to any warranty claims and/or repairs.

Maritime installations require additional preparation, and additional service intervals may be needed given the maritime use. In general, IP ratings presuppose freshwater conditions VS maritime conditions, which are typically more “caustic” to IP fixtures (both internally and externally). A duty-cycle may also be needed when units are not in use. During times of high humidity and colder temperatures, condensation may occur internally so the fixture may require a duty-cycle to bring it up to running temperature, allowing any accumulation of moisture to be expelled via the vent valve. Recommendations can change based on installation environmental circumstances. A waterproof dome or similar device is recommended for use in permanent outdoor installations. When using a dome, refer to manufacturer recommendations for duty-cycle.

NOTE: NOT ALL FEATURES LISTED ARE AVAILABLE ON ALL FIXTURES; THE FOLLOWING INSTRUCTIONS MAY NOT APPLY. CONTACT SUPPORT FOR ADDITIONAL DETAILS.

Exterior Maintenance: Inspect the exterior every 30-days. The unit must be powered off/disconnected. The chassis should be inspected for any signs of contaminants. Inspect optics to determine if the lens is obstructed, then clean optics and chassis accordingly. Based on initial finding, schedule maintenance accordingly, keeping in mind that exterior maintenance will be required. Even if the luminaires are NOT in use, maintenance will still be needed given its location (exterior use). The use of a durable type of wax on the chassis is recommended since it will help prevent contaminant build up. Inspect both power and data lines for any signs of contaminants or corrosion. Periodically reapplying di-electric grease, especially in coastal environments. If any signs of corrosion/contaminants are present, clean thoroughly, and/or replace connectors, then reapply di-electric grease. Typically, this should be done annually, or any time an opportunity presents itself. As a preventive measure, annual replacement of both vent valves is recommended. The vent valve membrane can become contaminated and/or clogged causing improper venting of humidity within the luminaire. Inspect all mounting hardware as a precaution.

Interior Maintenance: Inspect the interior every 30-days. The unit must be powered off/disconnected.

- Inspect zoom/focus mechanism, clean optics, lubricate linear bearings (Krytox oil) as needed, inspect belts for wear
- Inspect all rotating effect wheels, manually rotate them, note any resistance
- Inspect all remaining rotating belts for any wear
- Inspect all fans, clean as needed, check rotation, check connections
- Inspect CMY module, manually move flags and check for signs of resistance, and if needed, clean guide rods first, then reapply a thin layer of grease (moly lube)
- Clean interior with low-volume compressed air, then clean optics prior to reassembly of head covers

Although the base has limited moving parts, the pan belt should also be inspected for wear. Remember to always perform an IP test anytime a cover is removed.

There is no specific time frame regarding the routine replacement of parts such as belts/stepper motors, PCBs, or LEDs. These items should only be replaced on an as needed bases, except for cooling fans, which should be replaced once the luminaries reach 10,000-hours. This is a prophylactic measure intended to keep the unit running as cool as possible, insuring proper function of all internal components. A complete service breakdown is available, please contact service@elationlighting.com for any needed parts or manuals.

SAFETY GUIDELINES

This device is a sophisticated piece of electronic equipment. To guarantee a smooth operation, it is important to follow all instructions and guidelines in this manual. Elation Professional is not responsible for injury and/or damages resulting from the misuse of this device due to the disregard of the information printed in this manual. Only the original included parts and/or accessories for this device should be used. Any modifications to the device, included and/or accessories will void the original manufacturer's warranty and increase the risk of damage and/or personal injury.



PROTECTION CLASS 1 - FIXTURE MUST BE PROPERLY GROUNDED



THERE ARE NO USER SERVICEABLE PARTS INSIDE THIS UNIT. DO NOT ATTEMPT ANY REPAIRS YOURSELF; DOING SO WILL VOID YOUR MANUFACTURER'S WARRANTY. DAMAGES RESULTING FROM MODIFICATIONS TO THIS FIXTURE AND/OR THE DISREGARD OF SAFETY INSTRUCTIONS AND GUIDELINES IN THIS MANUAL VOID THE MANUFACTURER'S WARRANTY AND ARE NOT SUBJECT TO ANY WARRANTY CLAIMS AND/OR REPAIRS.



**DO NOT PLUG FIXTURE INTO A DIMMER PACK!
NEVER OPEN THIS FIXTURE WHILE IN USE!
UNPLUG POWER BEFORE SERVICING FIXTURE!
NEVER TOUCH FIXTURE DURING OPERATION, AS IT MAY BE HOT!
KEEP FLAMMABLE MATERIALS AWAY FROM FIXTURE!**

DO NOT shake the device, and avoid brute force when installing and/or operating the device.

DO NOT operate the device if the power cord is frayed, crimped, damaged, and/or if any of the power cord connectors are damaged and do not insert into the fixture securely with ease.

NEVER force a power cord connector into the device. If the power cord or any of its connectors are damaged, replace it immediately with a new one of a similar power rating.

When installing the fixture in a suspended environment, always use mounting hardware that is no less than M10 x 25 mm, and always install the fixture with an appropriately rated safety cable.

Always disconnect the fixture from the main power source before performing any type of service and/or cleaning procedure.

Only handle the power cord by the plug end; never pull out the plug by tugging the wire portion of the cord.

Consistent operational breaks will ensure the fixture functions properly for many years.

ONLY Use the original packaging and materials to transport the fixture for service.

OVERVIEW

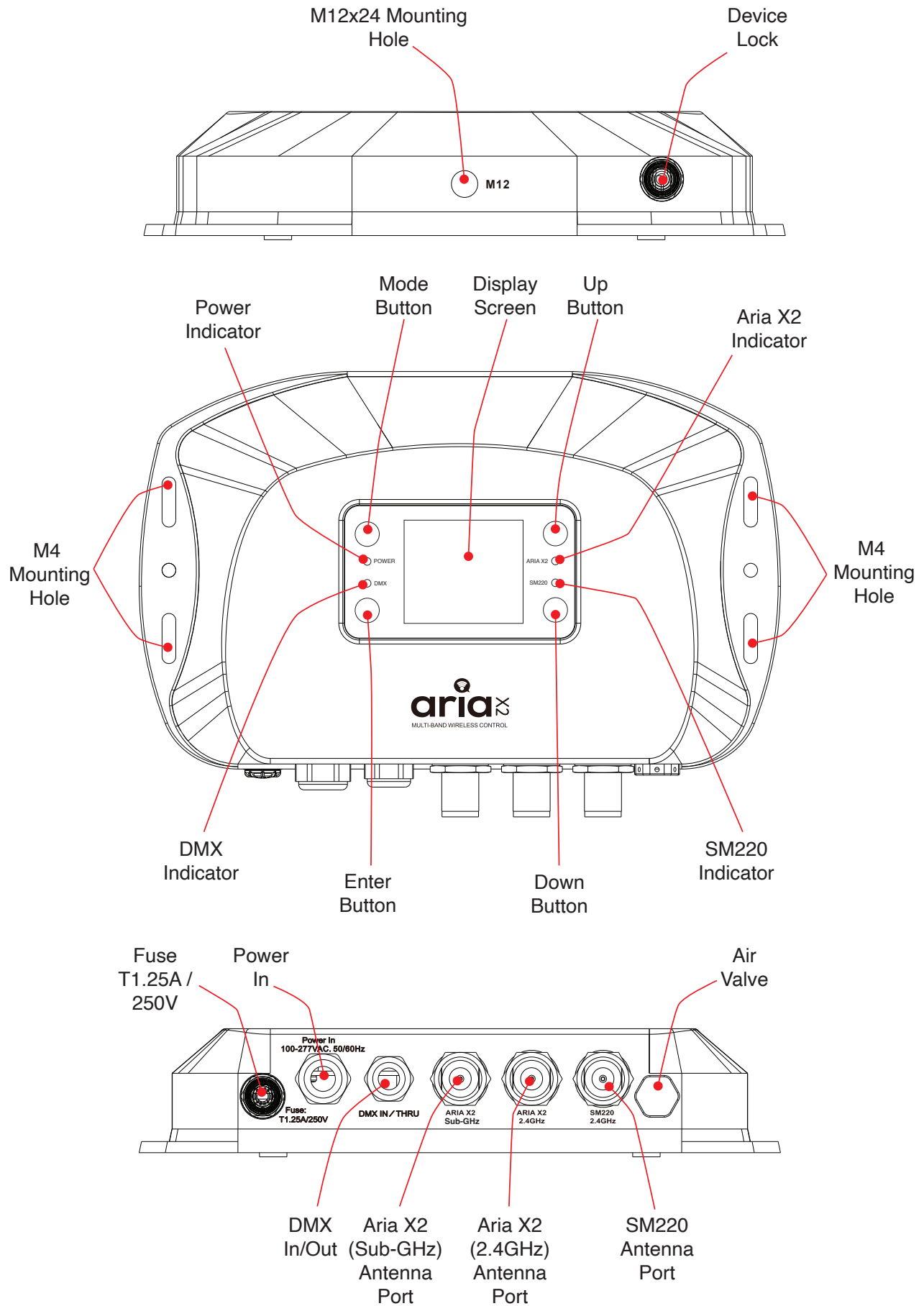

CONNECTIONS

AC CONNECTIONS

This device is rated for 100-277V 50/60Hz, and accepts AC mains power within that range. Do not connect it to power outside this range. Note that the device uses a T1.25A/250V fuse. Damage resulting from incorrect connection is not covered under warranty.

DMX CONNECTIONS:

The DMX connection is a wire gland configured for 5-pin DMX. **Please note that this DMX connection can be used for either an input or an output signal, as defined in the system menu.**

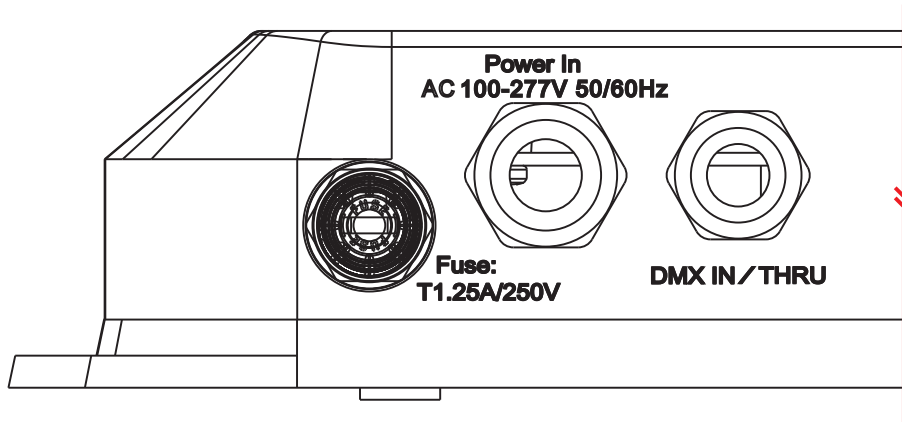

INSTALLATION INSTRUCTIONS



DISCONNECT POWER BEFORE PERFORMING ANY MAINTENANCE!



ELECTRICAL CONNECTIONS

A qualified electrician should be used for all electrical connections and/or installations.



USE CAUTION WHEN POWER LINKING OTHER MODEL DEVICES AS THE POWER CONSUMPTION OF OTHER MODEL DEVICES MAY EXCEED THE MAXIMUM POWER OUTPUT OF THIS DEVICE. CHECK SILK SCREEN FOR MAXIMUM AMPS.



THE ARIA X2 IPH BRIDGE IS DESIGNED TO BE TRUSS-MOUNTED; HOWEVER, IT CAN BE USED STAND-ALONE, WHERE THE DEVICE MUST SIT ON A FIRM FLAT SURFACE.

Device **MUST** be installed following all local, national, and country commercial electrical and construction codes and regulations.

Shielded cables must be used with this device in order to ensure compliance with Class B FCC limits.

INSTALLATION GUIDELINES

WALL MOUNT INSTALLATION

Thread the safety cable loop into the M12x24 mounting hole on the top of the device, as shown in the below left image. Use four (4) M4 mounting screws of the appropriate weight rating to secure the device to the mounting surface via the mounting tabs on each side of the device, circled below right image. Always consult with a professional equipment installer to ensure that the mounting surface is capable of supporting the weight of the device and any associated accessories and cables. Lastly, link a safety cable of the appropriate weight rating through the cable loop and attach to a secure mounting point.

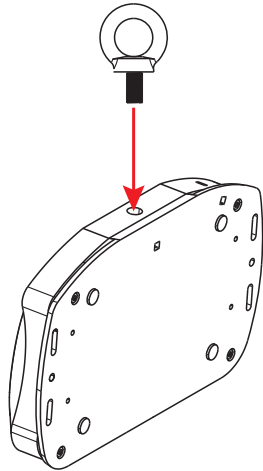

**SAFETY CABLE
LOOPE
D THROUGH
CABLE LOOP**

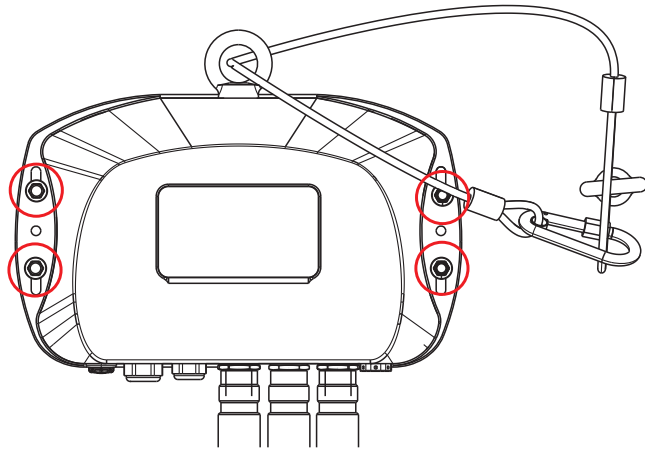

INSTALLATION GUIDELINES

DIN RAIL ADAPTERS

Secure two DIN Rail Adapters to the rear face of the X2 IPH Bridge, using two screws per adapter. Then, mount the X2 IPH Bridge by aligning the tabs of the DIN Rail Adapter with the slot of the DIN rail. Slide the X2 IPH Bridge onto the rail until it clicks or locks securely into place.

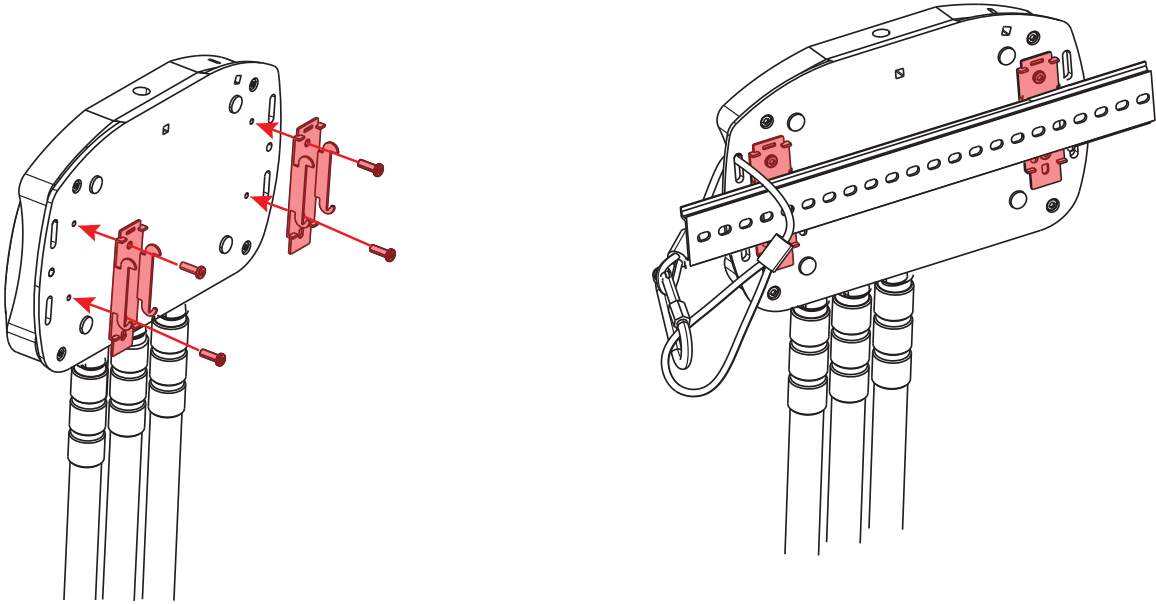

INSTALLATION GUIDELINES

CLAMP MOUNTING

To suspend this device from a truss or other elevated installation, thread a mounting clamp of the appropriate weight rating into the M12 mounting hole on the top face of the device, then use the clamp to attach the device to the truss. Always attach a safety cable of the appropriate weight rating by looping the cable through at least one of the device's mounting tabs, then loop the safety cable around the truss. Refer to the illustration below.

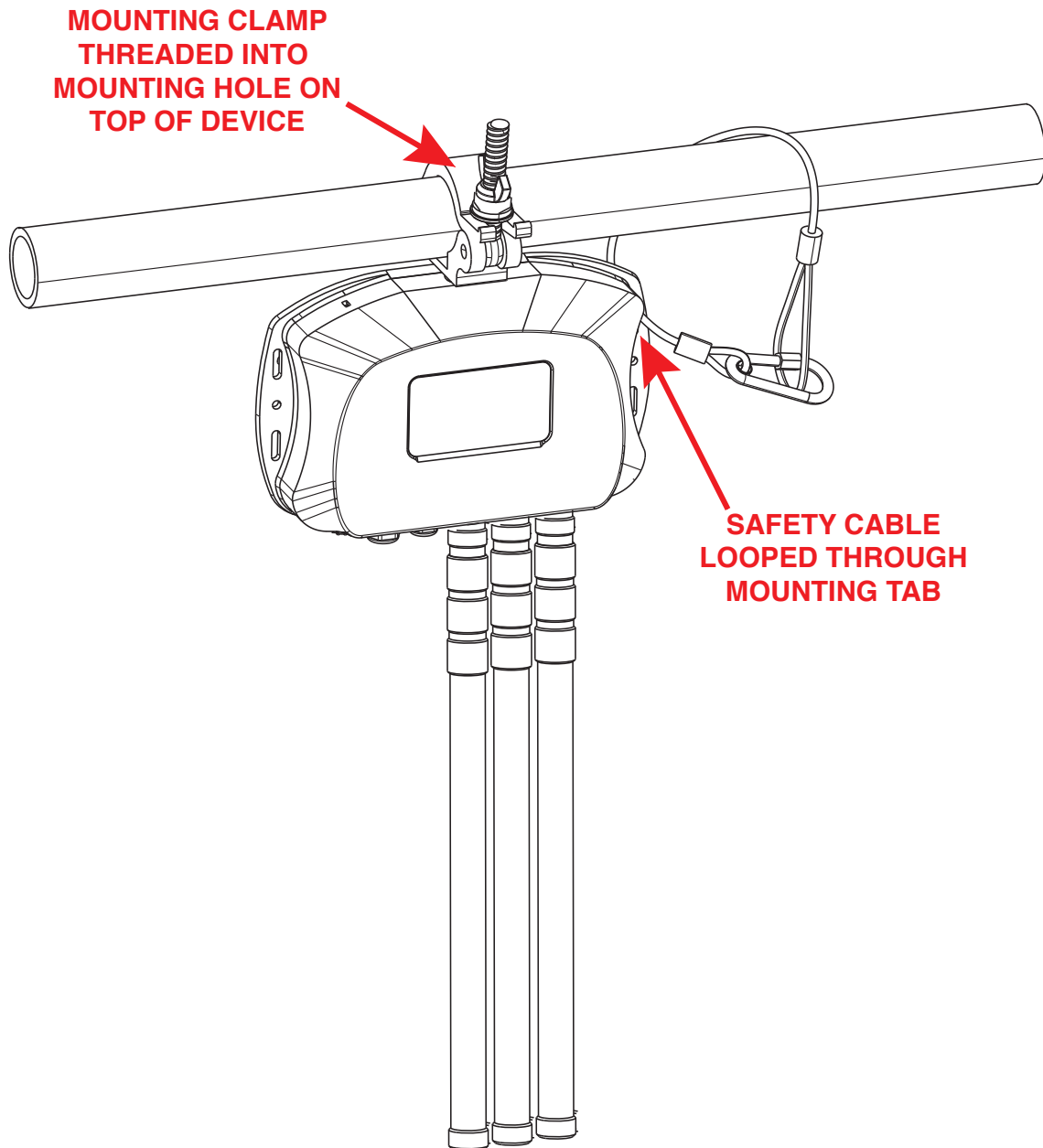

FALLING FIXTURES CAN CAUSE SEVERE INJURY OR SERIOUS EQUIPMENT DAMAGE! FOR THIS REASON, FIXTURES SHOULD BE INSTALLED AND INSPECTED ONLY BY QUALIFIED PERSONNEL. DO NOT INSTALL THE UNIT IF YOU LACK THE QUALIFICATIONS TO DO SO, OR IF YOU HAVE DOUBTS ABOUT THE SAFETY AND SECURITY OF THE INSTALLATION SETUP OR LOCATION!



ALWAYS ATTACH A SAFETY CABLE WHENEVER INSTALLING THIS FIXTURE IN A SUSPENDED ENVIRONMENT TO ENSURE THE FIXTURE WILL NOT FALL IF THE CLAMP FAILS.

SETUP

CONNECTING DMX CONTROLLER TO ARIA X2 IPH BRIDGE

This device has the flexibility to receive signal from the controller, and transmit the signal to other devices or additional bridges, via multiple protocols. Input and output signals may be received or transmitted via either of the Aria antennas, the SM220 antenna, or the physical DMX connection.

Any one of these 3 options (Aria, SM220, or physical DMX cable) can be used as the input to the device, and one or both of the remaining options can be used as the output. **However, please note that the option that has been selected for the input cannot be simultaneously selected for the output as well.** For example, in the illustration below, the device on the left has the physical DMX as its input, and therefore it is able to output via either Aria or SM220, or both.

When using a physical cable to link the units, please note that the DMX ports are cable glands intended for hard-wiring. The single DMX port should include wiring for both DMX input and output.

Selection of which method will be the unit input, and which method or methods will be the unit output, is done in the Bridge sub-menu of the System Menu. Please refer to the **System Menu** section of this manual for additional details.



SYSTEM MENU





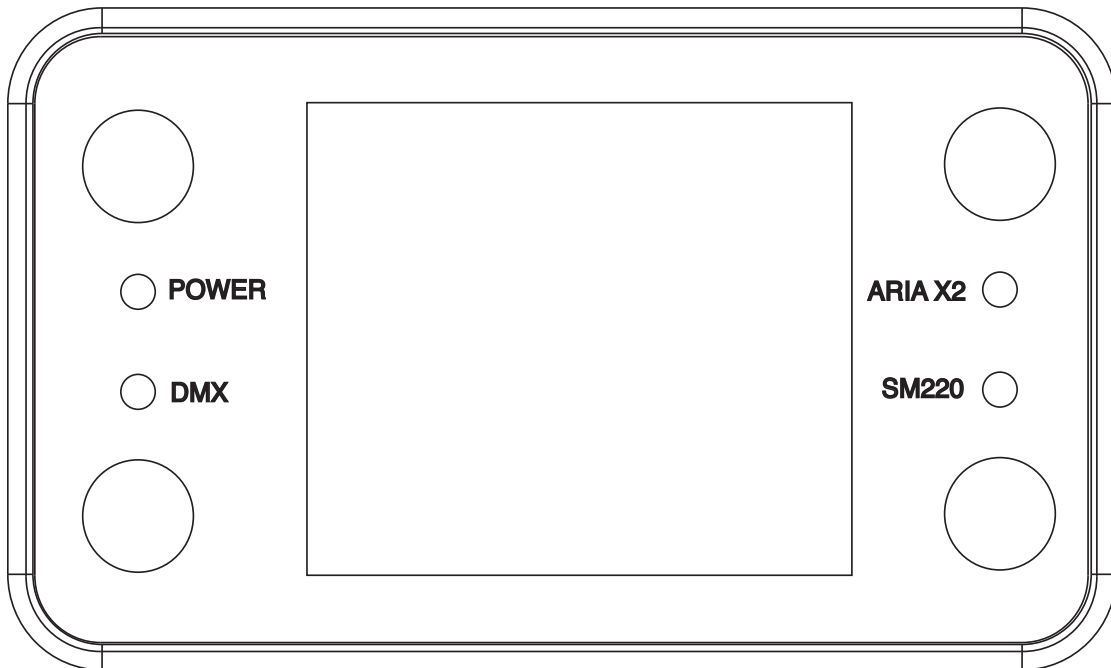

The Aria X2 Bridge features an LCD display screen with 4 control buttons, which can be used to easily adjust any device settings. Button functions and locations are as described below:

- **MODE** (top left) - Cycles through main menu options, or returns to the main menu without making adjustments.
- **ENTER** (bottom left) - Selects the option currently displayed on the screen, and opens up the next sub-menu option if applicable.
- **UP** (top right) / **DOWN** (bottom right) - Scrolls up or down through the list of options for the currently selected menu.

Additionally, the control panel includes four (4) indicator lights that signify that the unit is receiving power and broadcasting/receiving over DMX, Aria X2, and/or SM220.



SYSTEM MENU

MAIN MENU	OPTIONS / VALUES (Default Settings in BOLD)		
Aria Settings 	Frequency	2.4 GHz	
		Sub GHz US	
		Sub GHz EU	
	2.4 GHz Ch	00 - 15	
	Sub GHz Ch	00 - 09	
	Mesh Enable	On / Off	
Bluetooth	On / Off		
SM220 Settings 	SM220 Enable	Yes / No	
	Channel	00 - 14	
Bridge 	Aria In	SM220 Out	
		DMX Out	
		Both Out	
		Disable	
	SM220 In	Aria Out	
		DMX Out	
		Both Out	
		Disable	
	DMX In	Aria Out	
SM220 Out			
Both Out			
Display 	Timeout	Off - 10 min	
	Passcode	Enable / Disable	
	Edit Passcode	Passcode	xxx xxx
	Screen Rotation	Yes	
		No	
Auto			
Label 	Rename	AaBbCcDd...()-+0123456789 (Default = Aria X2 B)	
	Modify		
Service 	Enter Passcode (50)	Factory Restore	Yes / No
Information 	Software Version	Vx.xx	
	RDM UID	xxxxxx	
	Label	xxxxxx	

FREQUENCY & WIRELESS LOCATION GUIDELINES

2GHz Versus Sub-GHz Frequencies

Sub-GHz frequencies offer greater resilience and range than higher frequencies, making them ideal for reliable communication over extended distances or in challenging environments.

Sub-GHz devices operate at frequencies below 1 GHz, facilitating the transmission of signals over considerable distances and the penetration of physical obstructions such as walls and buildings. These frequencies are also subject to less interference than those in the 2.4-GHz band, which is heavily utilized by wireless devices, resulting in a congested spectrum.

Installation Recommendations:

With the many factors that affect and/or interrupt a wireless signal such as walls, glass, metal, objects, and people, it is highly recommended to:

- Install devices a minimum of 9.8 ft. (3m) above audiences and/or ground level where practical.
- Adjust the wireless antenna in a vertical upright position
- Position devices in direct line of sight of the controlling E-FLY device

Careful planning and testing of the selected installation location is critical to ensure optimum and reliable wireless operation.

**9.8 ft (3m)
Above Ground**

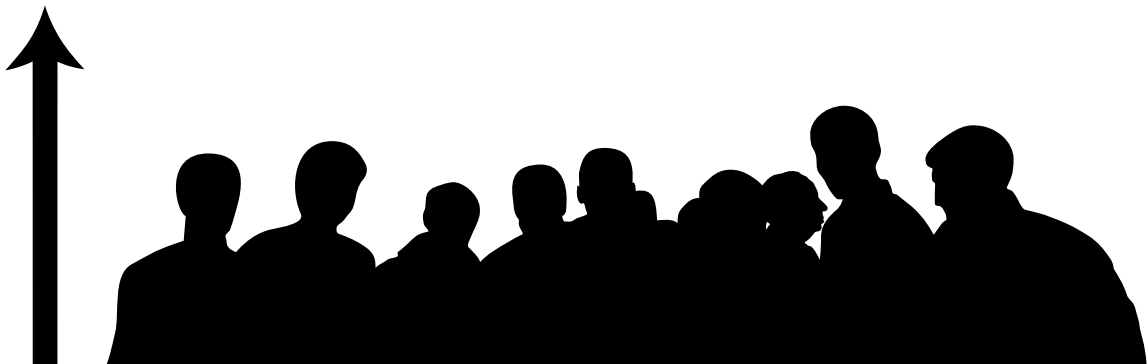

FIRMWARE UPDATE

1. First, turn on the fixture and ensure that Bluetooth is enabled.
2. Next, open the Aria X2 app on your phone and press the 'Refresh' button. The app will search for devices and display the current software version of the fixture and Aria module.
3. To update the fixture, press 'Update', select 'Aria X2', click 'Update Radios', then click 'Update Fixture'.
4. Click the upload icon, select the fixture update file from your phone, and then click 'Update 1 Radio'. The fixture will begin updating, and after it finishes, the software file version and update date will be displayed.
5. To update the Aria module, follow the same steps, but select 'Update Aria' instead.

MAINTENANCE GUIDELINES

DISCONNECT POWER BEFORE PERFORMING ANY MAINTENANCE!

A disconnect device may be :

- the plug on the power supply cord or equipment for plugging the device in directly
- an appliance coupler
- an isolating switch
- a circuit breaker
- any equivalent means for disconnecting the device from the power source

FUSE REPLACEMENT

Locate and remove the unit's power cord. Once the cord has been removed, locate the fuse holder next to the power socket. Insert a flat-head screw driver into the slot, and gently turn the cover of the fuse holder. Remove the bad fuse, and replace with a new one. Double check silkscreen for fuse value (T1.25A/250V).

CLEANING

Frequent cleaning is recommended to ensure proper function, optimized light output, and an extended life. The frequency of cleaning depends on the environment in which the fixture operates: damp, smoky, or particularly dirty environments can cause greater accumulation of dirt on the fixture's optics. Clean the external lens surface periodically with a soft cloth to avoid dirt/debris accumulation.

NEVER use alcohol, solvents, or ammonia-based cleaners.

MAINTENANCE

Regular inspections are recommended to ensure proper function and extended life.

There are no user serviceable parts inside this fixture, please refer all other service issues to an authorized ADJ service technician. Should you need any spare parts, please order genuine parts from your local ADJ dealer.

Please refer to the following points during routine inspections:

- A detailed electrical check by an approved electrical engineer every three months, to make sure the circuit contacts are in good condition in order to prevent overheating.
- Be sure all screws and fasteners are securely tightened at all times. Loose screws may fall out during normal operation, resulting in damage or injury as larger parts could fall.
- Check for any deformations on the housing, rigging hardware, and rigging points (ceiling, suspension, trussing).
- Electric power supply cables must not show any damage, material fatigue, or sediments.
- **NEVER** remove the ground prong from the power cable.

TORQUE SETTINGS FOR SCREWS

IN ORDER TO MAINTAIN THE IP67 RATING ON THE LIGHTING FIXTURES, ALL SCREWS MUST BE TIGHTENED TO THE FOLLOWING TORQUE SPECIFICATION USING A TORQUE DRIVER.

Refer to the table and diagram below for torque specifications.

TORQUE DRIVERS (Recommended): UTICA TS-30 (shown)

ALTERNATE DRIVERS:

- Proto J6107A
- Wiha 28887



CAUTION! DO NOT OVER TORQUE SCREWS, AS THIS CAN CAUSE LEAKAGE ISSUES!

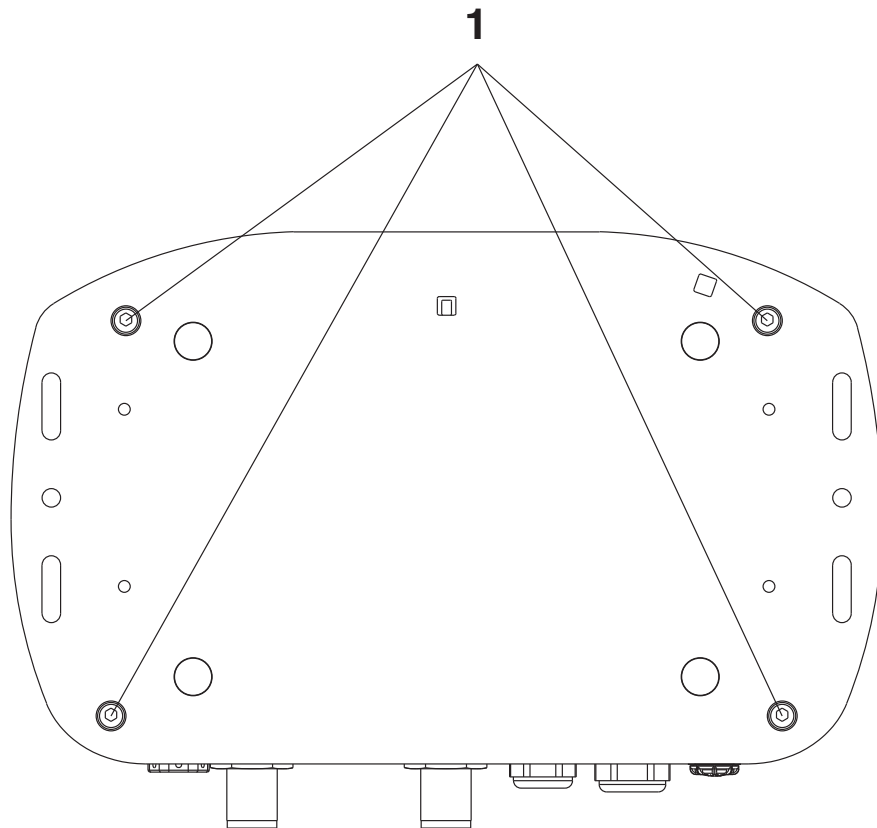

NO.	LOCATION	QUANTITY	TORQUE
1	Rear Cover	4	9.4 ± 0.4 Lb-in (10.8 ± 0.5 Kg-cm)

IP TEST PARAMETERS

Following any repair or maintenance procedure that requires disassembly of the fixture, use Elation's IP Tester to confirm the IP integrity of the fixture. The air valve is located on the back panel next to the display screen, as shown in the diagram below. Please contact ADJ Service for information regarding the Elation IP Tester, or visit the product information page online at: <https://www.elationlighting.com/ip-tester>

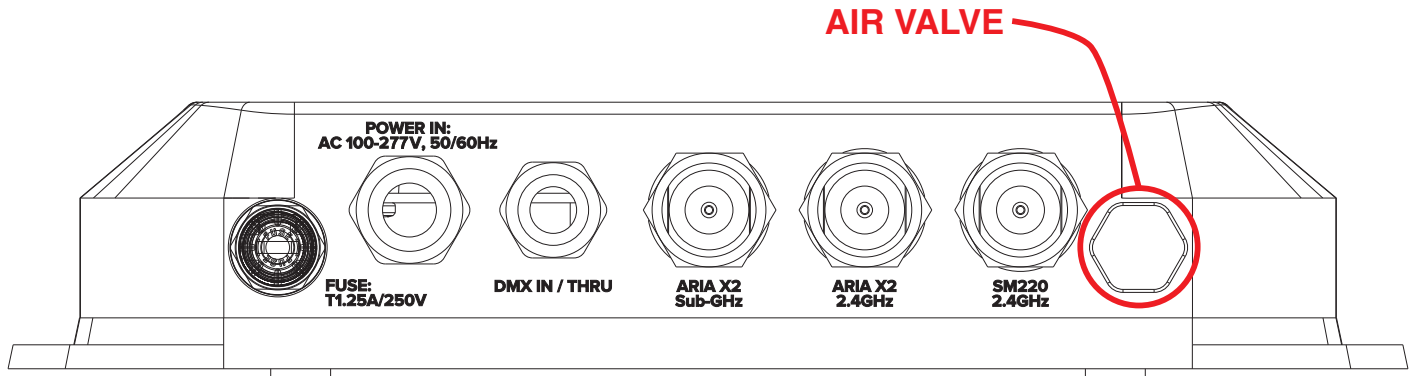

CAUTION! THE USE OF PROTECTIVE GLOVES AND SAFETY GOGGLES IS STRONGLY RECOMMENDED WHILE PERFORMING THE IP PRESSURE TEST! AVOID PLACING YOUR FACE, EYES, HANDS, ETC IN CLOSE PROXIMITY TO THE FIXTURE'S LENS WHILE PERFORMING THE TEST!

DE-HUMIDIFICATION: IP67 devices operating in high-humidity environments may experience residual fogging or condensation. Such fogging will not damage the device, and can be removed using the following procedure: position the unit with the air valve pointing upwards, then open the air valve and run the unit for 1-2 hours after reaching operating temperature. Then, while the fixture is still hot, re-install the air valve and allow the unit to cool down. Please note that this procedure should be performed in a dry, air-conditioned environment. Avoid additional fogging by drying the device completely before placing into a road case.



IP PRESSURE TESTING PARAMETERS				
Vacuum Test Target Value	Vacuum Test Minimum	Pressure Test Target Value	Pressure Test Minimum Value	Hold Time
-5.8 psi (-40 KPa)	-5.1 psi (-35 KPa)	5.1 psi (35 KPa)	3.6 psi (25 KPa)	30 sec

SPECIFICATIONS

Features:

Single DMX Universe
Sub-GHz and 2.4GHz bands, and Bluetooth
Bluetooth 4.2
Configuration via App or Front panel
Wireless to DMX or DMX to Wireless
IP67 Housing

Supported Protocols:

DMX512
Proprietary 802.15.4
Aria X2 Mesh Protocol
Bluetooth 5.2 (BLE)
Aria X2 Serial Protocol (This is our proprietary serial protocol for communicating with a variety of fixtures.)

RF Characteristics:

Frequency range

- 2404-2480 MHz
- 863-870 MHz (EU)
- 902-928 MHz (US)

Radio module: Aria X2
Interference mitigation
CSMA
Adaptive frequency hopping (on the roadmap)
OTA updates

Power:

Power Input: AC100-277V 50/60Hz
Power Consumption: 2.2W (19mA) @ 120V/60Hz, 2.2W (10mA) @ 230V/50Hz
Power Fuse: T1.25A/250V. (5 x 20mm)

Physical:

IP67 Enclosure
Front panel digital screen
M12 Threads
Max ambient operating temp range: -4°F to 113°F (-20°C to 45°C)
Max operating humidity: <75%
Storage temperature: 77°F (25°C)

Dimensions and Weight:

Length: 9.2" (233.70mm)
Width: 20.1" (509.89mm)
Height: 1.8" (46.00mm)
3.7lbs (1.66kgs.)

DIMENSIONAL DRAWINGS

Drawings not to scale

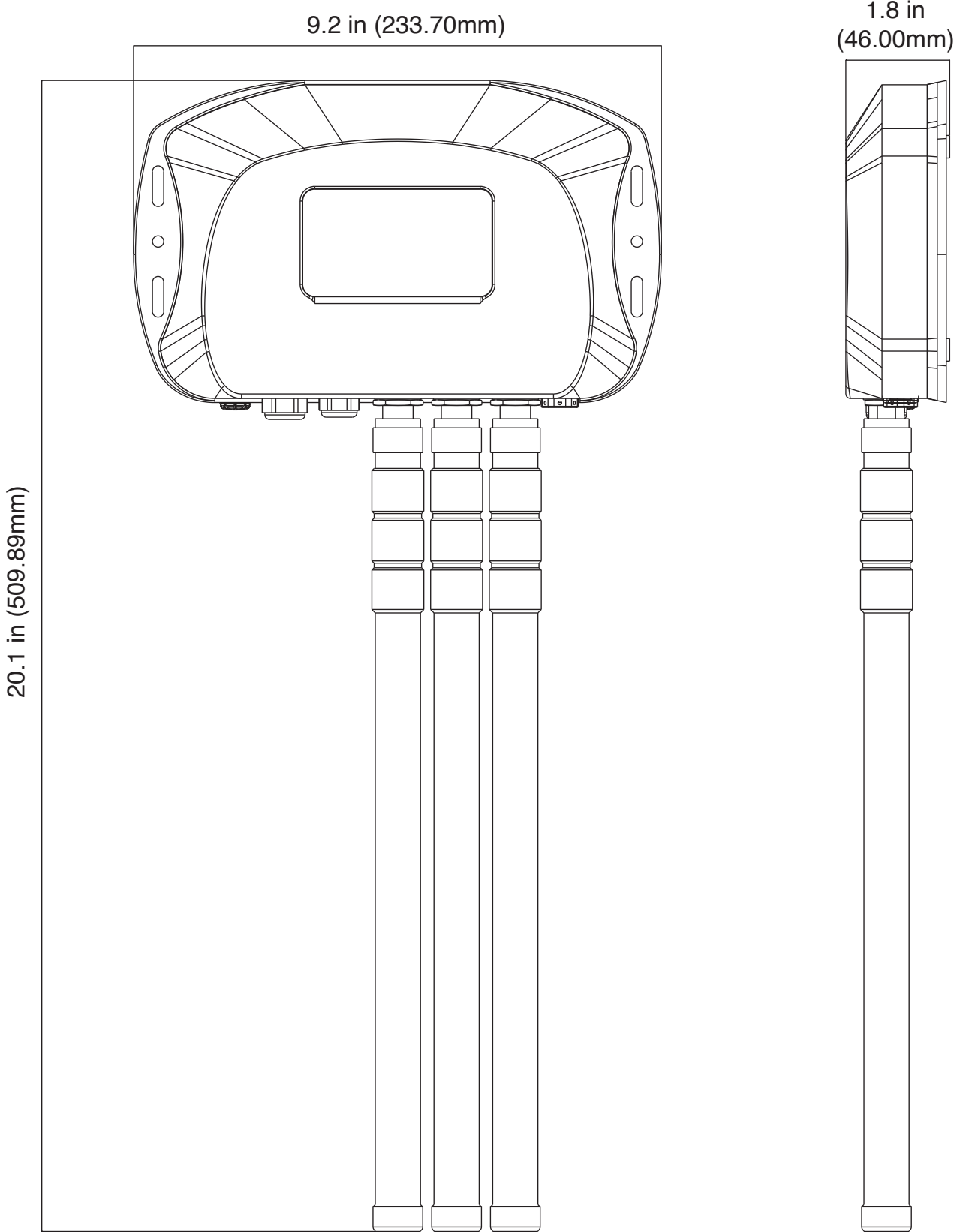

FCC STATEMENT

Changes or modifications to this unit that have not been expressly approved by the party responsible for compliance could void the user's authority to operate the equipment. NOTE: This equipment has been tested and found to comply with the limits for a Class B digital device, pursuant to Part 15 of the FCC Rules. These limits are designed to provide reasonable protection against harmful interference in a residential installation. This equipment generates uses and can radiate radio frequency energy and, if not installed and used in accordance with the instructions, may cause harmful interference to radio communications.

However, there is no guarantee that interference will not occur in a particular installation. If this equipment does cause harmful interference to radio or television reception, which can be determined by turning the equipment off and on, the user is encouraged to try to correct the interference by one or more of the following measures:

- Reorient or relocate the receiving antenna.
- Increase the separation between the equipment and receiver.
- Connect the equipment and the receiver to outlets on separate electrical circuits.
- Consult the dealer or an experienced radio/TV technician for help.

This equipment complies with FCC's and IC's RF radiation exposure limits set forth for an uncontrolled environment. The antenna(s) used for this transmitter must be installed and operated to provide a separation distance of at least 20 cm from all persons and must not be collocated or operating in conjunction with any other antenna or transmitter. Installers must ensure that 20cm separation distance will be maintained between the device and users.

This device contains licence-exempt transmitter(s)/receiver(s) that comply with Innovation, Science and Economic Development Canada's licence-exempt RSS(s). Operation is subject to the following two conditions:

1. This device may not cause interference.
2. This device must accept any interference, including interference that may cause undesired operation of the device.



